







WaterflowControl

WFC-FS-AVA

Manual Backwash Filter 25mm & 50mm

Contact Us:

-  (02) 9948 0699
-  info@waterflowcontrol.com.au
-  www.waterflowcontrol.com.au
-  37 / 317-321 Woodpark Rd, Smithfield NSW 2164



Scope of Supply

WFC Avanti RF Australia, consisting of:

1	Top section in DR brass
2	Union connection fitting with seals
2a	Union connection with dual check valve
3	Transparent bowl with filter element
4	Hose connection for flushing water supply
5	Turning knob for the backwashing element

The product is approved to ATS 5200.103; Technical Specification for plumbing and drainage products Part 103: Water treatment systems (other than those specified in AS/NZS 3497).

Intended use

The filters are primarily used for filtering sediments from water.

They protect plumbing fixtures and fittings from malfunctioning, and against damage caused by foreign particles such as rust, swarf and sand.

The filters are not intended for use with chemically treated circulating water.

Suitable Applications

- Domestic water supply
- Commercial use and high-rise buildings
- Industrial
- Food preparation areas and beverage equipment as a pre-filter

In applications with water containing coarse impurities, a coarse dirt separator must be used.

The filter is not suitable for oils, greases, solvents, soaps and other lubricating media nor for the separation of water-soluble substances.

Function

Untreated water flows through the filter where impurities > 90 µm are trapped by the filter screen and removed. The filter screen can be cleaned by backwashing as required.

For the backwashing process, the wastewater connection is opened by turning the turning knob (5) and the backwashing element is also turned.

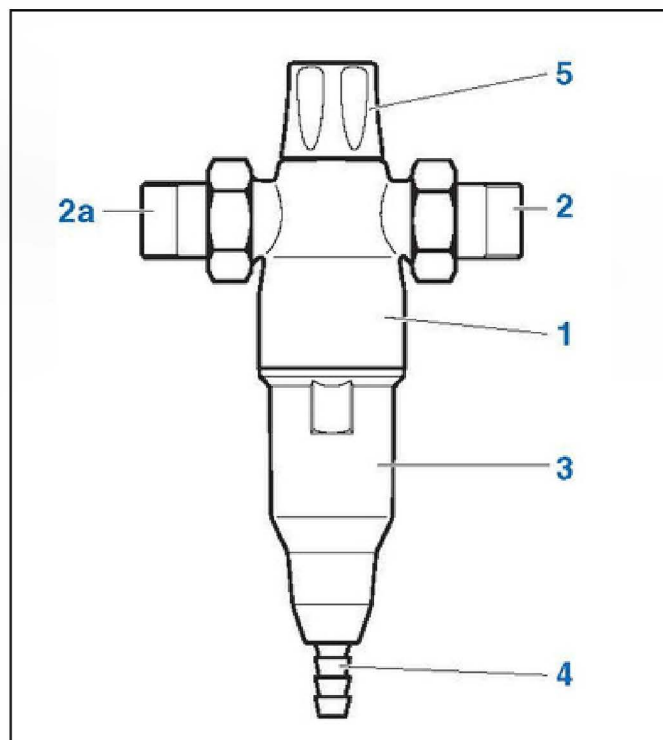

The particles on the filter cloth are removed by suction from the suction-ring backwashing system and then washed out.

Installation

The unit must be installed by a licenced tradesperson to AS/NZS 3500.

A connection must be available for draining the flushing water.

The filter installation must be protected against freezing conditions, solvent vapours, fuel oil, chemicals of all kinds, UV radiation and heat sources above 40 °C.

If the unit has been dropped or damaged, plastic parts must be replaced even if there is no visible damage. A cover is recommended where the filter is installed in direct sunlight.

The unit should be installed to allow clear access for removal.

Observe the local installation regulations, general guidelines, general hygiene regulations and the technical specifications.

A connection to the sewage system (discharge) of min. DN 40 should be available.

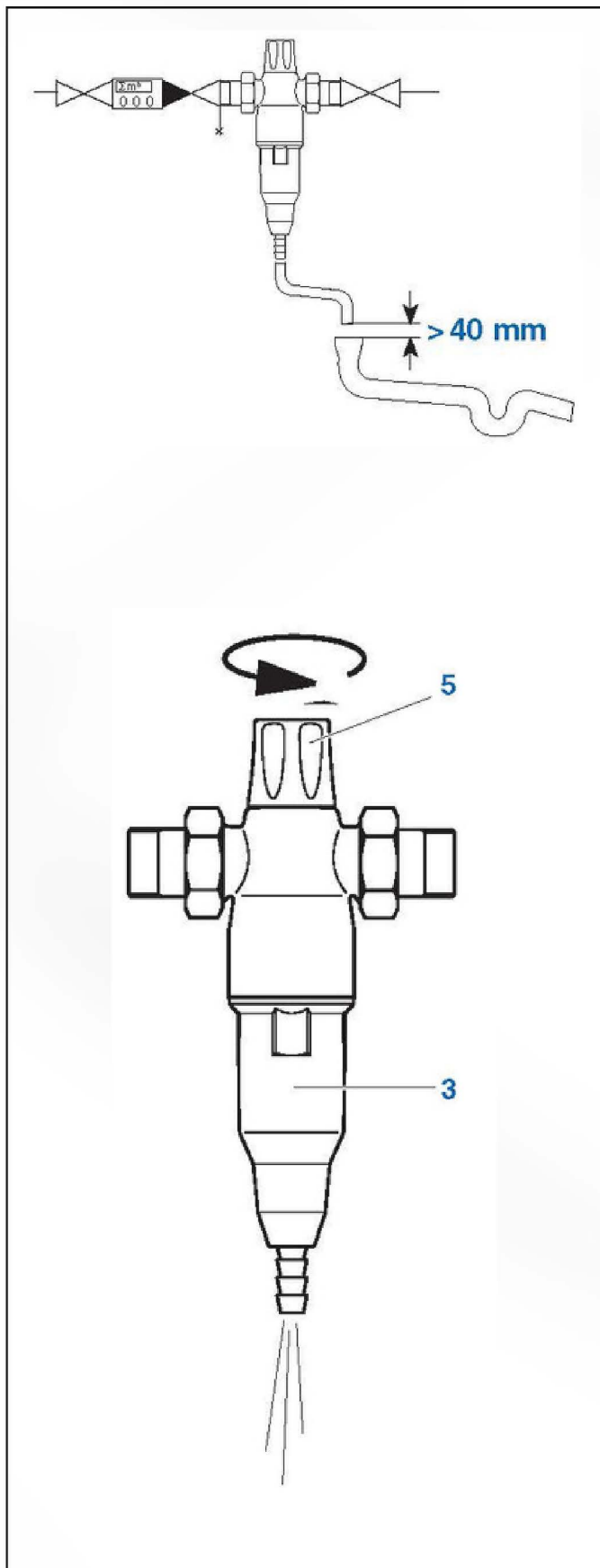

Attention: The installation site must be protected against frost and must ensure the protection of the filter against e.g. solvent vapours, fuel oil, leas, chemicals of any kind, UV radiation and heat sources above 40 °C.

Attention: Keep the plastic parts free from grease, solvents and acidic as well as basic detergents. The plastic parts must be replaced even if there is no visible damage after severe concussions and shocks e.g. due to the use of unsuitable tools or if dropped on stone floors etc (danger of bursting). Avoid extreme pressure impact.

Installation

Install filter according to its nominal size in cold water pipes of the same dimensions and before the equipment to be protected. Install stop valves before and after the filter.

Assemble the connection fittings (2) in the pipe and install filter in flow direction (see flow direction arrow) in the horizontal cold water pipe (see installation sketch).

Connect flushing water connection with hose to the waste drain or provide a collection basin (capacity approx. 15 l).

Please note: The flushing water hose must be installed at a minimum distance of 40mm above the highest possible waste water level (free discharge).

Startup

Check the filter and the flushing water pipe for proper installation.

The stop valves must not be opened yet. Check the transparent bowl (3) for proper fit and then close the turning knob (5) by turning it clockwise.

Slowly open the stop valves before and after the filter and deaerate the water pipe at the next outlet downstream.

If the flushing water pipe is not connected to the waste water before backwashing, provide a collecting basin.

Open the turning knob counter-clockwise and continue until fully open. Reverse the procedure to close and complete the backwash. Check whether the filter is correctly sealed.

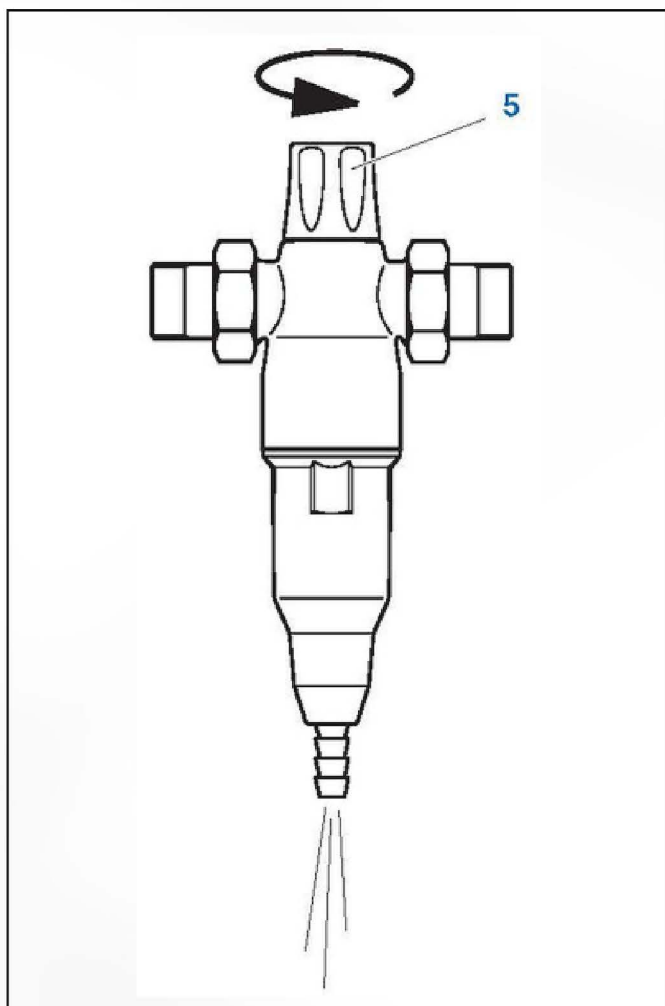

Operation

A backwash must be carried out as required to prevent dirt particles from settling on the filter cloth (or more frequently with higher amounts of dirt).

Before starting the backwash procedure, provide a collecting basin, if the flushing water pipe is not connected to the wastewater drain.

Backwashing

Open the turning knob (5) counter-clockwise and continue until fully open. Reverse the procedure to close and complete the backwash. Check whether the filter is correctly sealed.

The turning knob is equipped with a safety clutch. If turning too forcibly a latch jumps, this prevents damage to the locking system.

The plastic parts may only be cleaned with a soft, damp cloth. Do not use any solvents or detergents nor acid cleaners.

Troubleshooting

Fault	Cause	Action
Water pressure in system has dropped considerably; Water pressure drops considerably when water is bled (by more than 35% of the static pressure)	Dirty filter element	Carry out backwash
Flushing water outlet cannot be closed	Backwash element does not reach final position due to coarse particles of dirt	Fully open and close turning knob; repeat backwash several times

If the fault cannot be rectified using these notes, please contact a specialist firm or our Customer Service.

Flow-rate WFC-FS-AVA-25

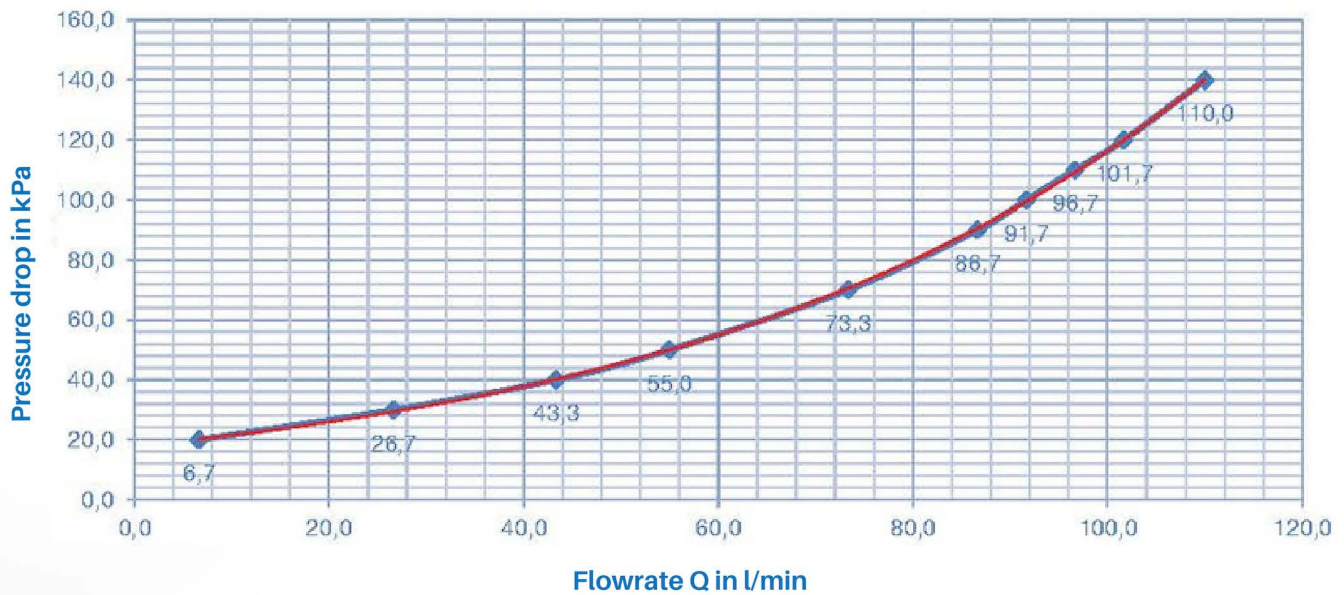

Flow-rate WFC-FS-AVA-50

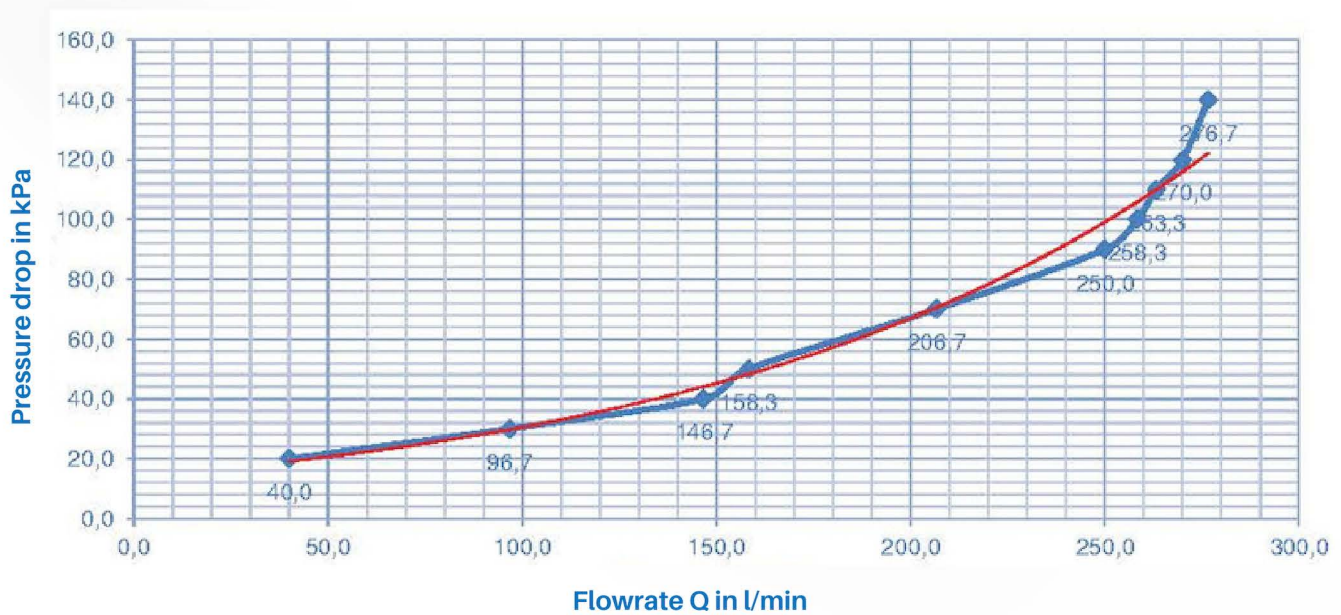

Specifications



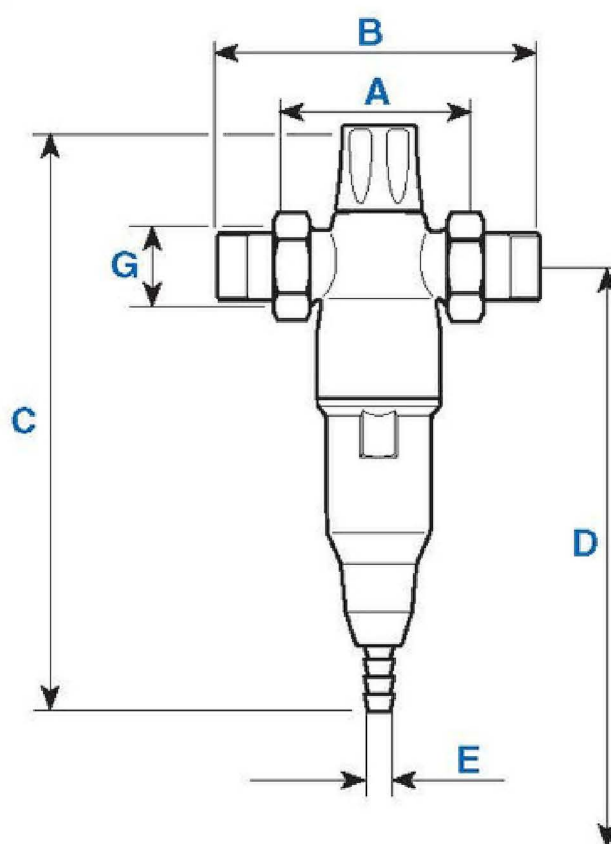

WFC-FS-AVA		Type	1"	2"
Nominal Connection Size		DN	25	50
Hose connection, diameter	E	mm	14	20
Flow rate at $\Delta p = 20$ kPa		m ³ /h	3,5	10,0
Flow rate at $\Delta p = 50$ kPa		m ³ /h	6,0	15,5
Filter screen		μ m	90/110	
Nominal pressure (PN)		kPa	1600	
Water temperature		°C	5 - 30	
Ambient temperature, max.		°C	5 - 40	
Overall length without fitting	A	mm	100	140
Overall length with fitting	B	mm	205	327
Total height	C	mm	278	370
Distance pipe centre to floor, min.	D	mm	400	450
Swivel nut thread	G		G 1 1/4" x R1"	G 2 1/4" x R2"
Distance pipe centre to wall, min.		mm	50	60
Operating weight, approx.		kg	2,2	5,4





WaterflowControl

For Further Information:

-  (02) 9948 0699
-  info@waterflowcontrol.com.au
-  www.waterflowcontrol.com.au
-  37 / 317-321 Woodpark Rd, Smithfield NSW 2164