







WaterflowControl

WFC-FS-VF2-FF

First Flush Diverter VF2 SS

Contact Us:

-  (02) 9948 0699
-  info@waterflowcontrol.com.au
-  www.waterflowcontrol.com.au
-  D1/20 Picrite Close, Pemulwuy, NSW



Model No: WFC-FS-VF2-FF Volume Filter VF2

For roof areas up to:	1200m ²
Rainwater Inlet diameter:	200mm
Outlet to storage tank:	150mm
Stormwater connection in manhole:	200mm
Height between rainwater inlet and outlet to tank:	32cm
316 S/S Filter easily removed for cleaning.	
Maximum TFR "Treatable Flow Rate"	10.00 L/s

How the First Flush Diverters work

1. As rain water arrives the water level builds up, and overtops the filter lip, so ensuring it is distributed evenly across the whole width of the filter cascade.
2. Pre-cleaning through the cascades. Larger dirt particles are washed across the cascades directly to the sewer.
3. Pre-filtered water then flows over the secondary filter (mesh size 0.55 mm). Due to the special structure of the sieve mesh, any dirt is washed directly into the sewer which means the filter is self-cleaning, low maintenance.
4. Cleaned water flows to the storage tank.
5. Dirt goes to the sewer.

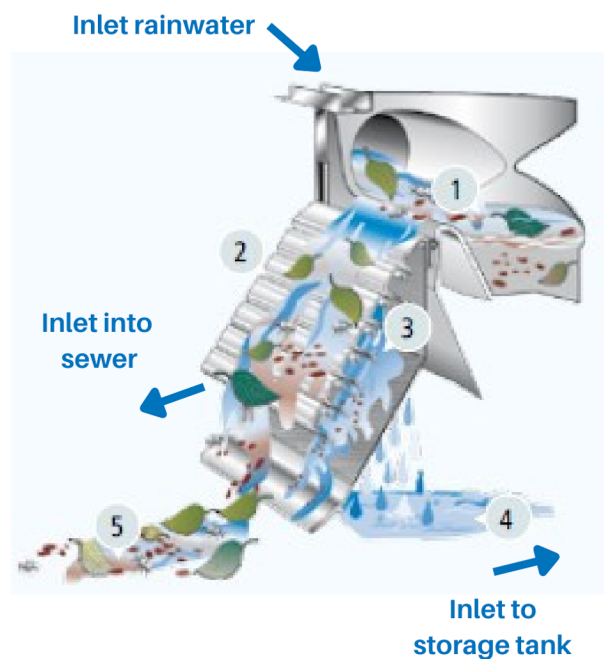

Dimensions

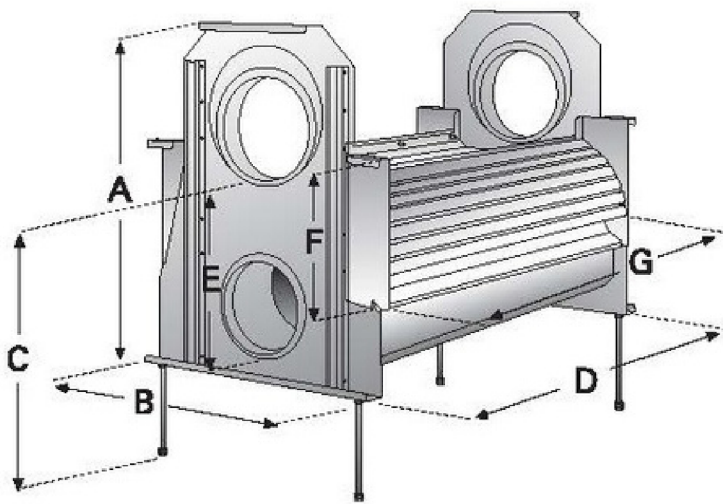

Filter	Inlet Rainwater	Outlet to sewer	Outlet to storage tank	A in mm	B in mm	C in mm	D in mm	E in mm	F in mm	G in mm	Mesh size	min. Ø man-hole	max water flow rate	Maximum Roof Area
VF2	1 x DN 200	1 x DN 200	1 x DN 150	670	540	475	390	325	275	320	550 my	1000	25.5 l/s	1200 m ²

Installation Guide

We recommend installing the filter in its working position. From experience in the "real world" we recommend use of short connection pipe lengths to any manhole chamber, pushed in from the outside through the chamber wall inlets into the corresponding connections of the filter. This will help to minimise the risk of the connecting pipes or the seals being displaced during the subsequent construction process. (settlement etc.)

When connected directly at the building site please make sure that all seals are set correctly. The pipes should not project into the filter more than 5 cm.

Manhole: Chamber diameter 100/200cm

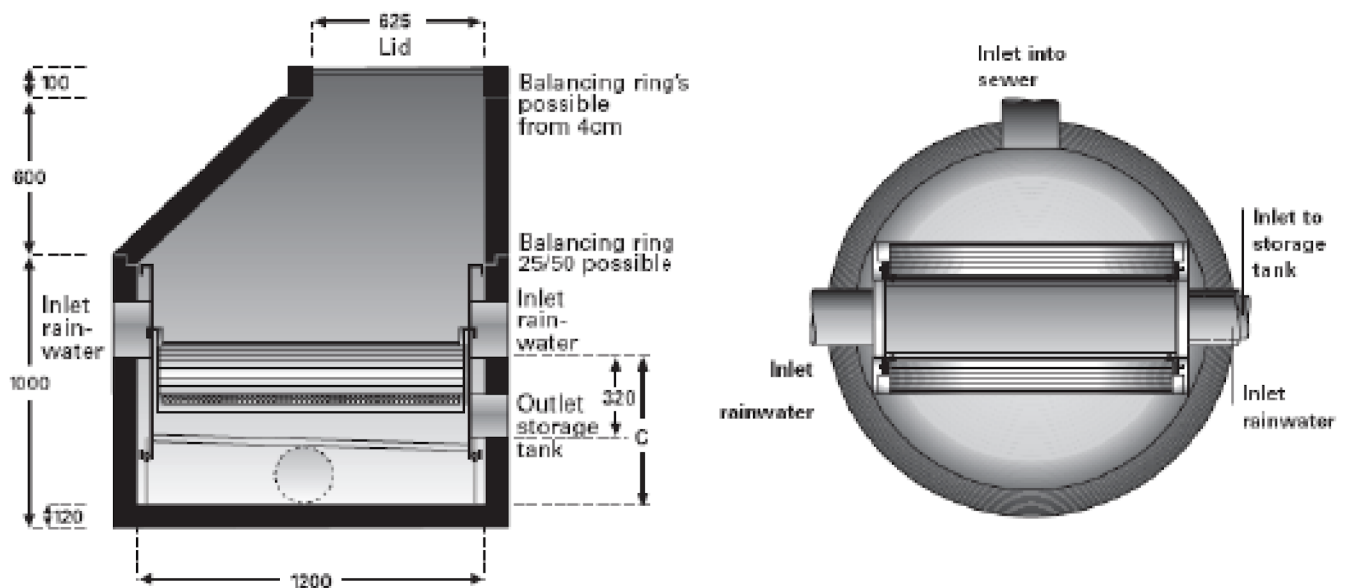

The filter should be installed perpendicular and horizontal. There are adjustable feet to accommodate small height differences. The manhole itself should be set level. The manhole chamber base should ideally have a gradient of approximately 5% or more towards the sewer outlet. This ensures any sediment is more easily rinsed away.

We strongly recommend that the distance between the manhole floor and the lower sump in the filter should be at least as big as the filter inlet diameter.

You can adjust this distance with the help of the adjustable feet (the threaded bars). You may wish to have your installer/drainage contractor prepare the manhole chamber according to the following conditions. The diameter of the chamber walls orifices will depend on the selected seals for the pipes.

Outlet to waste:

Base of outlet pipe = base of manhole

Inlet to storage tank

Base of the inlet pipe = x cm
(s. dates of the filter p. 4)
above base of manhole

2 x inlets rainwater:

Base of 2 No inlet pipes = 32cm from base of outlet to storage tank,
which is therefore 57cm from base (floor) of chamber

Installation Advice

- We recommend you remove the filter mesh unit before installation.
- Install the threaded bolts, length c. 25cm, and place the filter in the manhole.
- Now push the connection pipe (and sleeve pieces respectively) through the manhole wall into the corresponding sealing rings of the filter.
- Small height differences are then adjusted using the adjustable feet (threaded bolts).
- Check, with a spirit level, that water will be level in the filter's receiving sump for optimal performance.
- Replace the lamella filter mesh unit.

We also recommend covering the filter during installing to keep it clean (during any setting of concrete rings and lid etc.)

Optimal Installation Situation

- Bypass and inlet feed to both sides of filter.
- High security due to bypass installation, because of this you can connect to larger roof areas.
- Higher efficiency through inlet feed from both sides of filter.

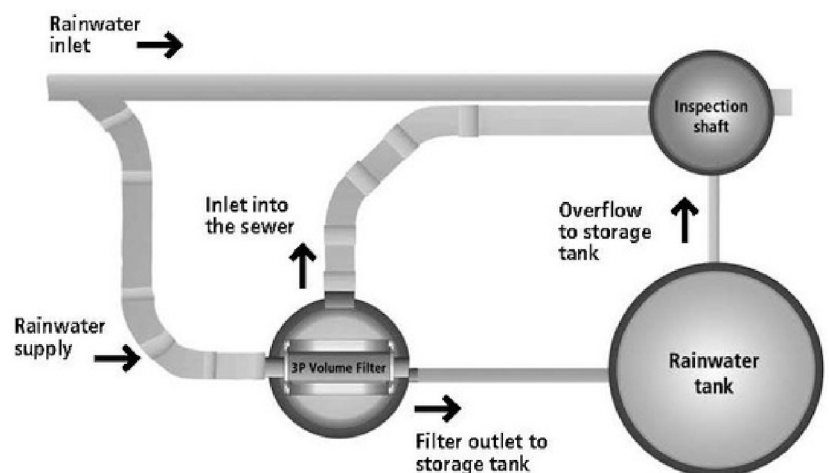

Cleaning the S/S Filter Screen

Monitor the filter regularly, clean if necessary.

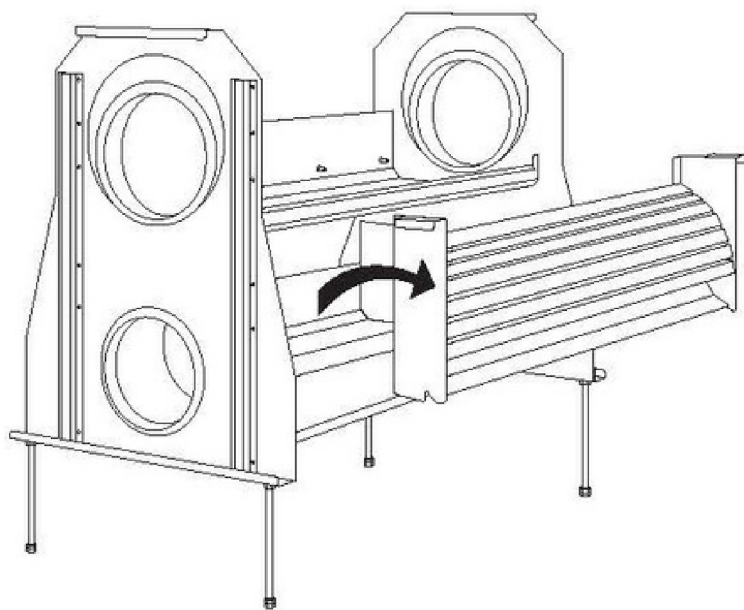

1. Once a year flush out the sump and manhole with a hose. The sump can be emptied through a little orifice in the sump floor. Therefore, the inlet to the tank should be sealed temporarily.
2. The lamella unit can be cleaned with a high-pressure cleaner but take care not to hold any lance too close to the delicate mesh, lest it damage the mesh itself.